

# LIFT RITE PALLET TRUCKS

## Titan Series

### FEATURES:

- ONE PIECE CAST PUMP
- 3 POSITION CONTROL HANDLE
- ADJUSTABLE PUSH RODS
- REINFORCED FRAME
- THICK THRUST PLATE WITH GREASE FITTINGS
- TRUE 3" LOWERED HEIGHT ON STANDARD SERIES
- PRECISION STEER WHEELS AND ROLLERS

POPULAR MODELS IN RED



## 2 YEAR PUMP WARRANTY

STANDARD SERIES:

3" LOWERED HEIGHT, 7 3/4" RAISED HEIGHT

5,500LB. CAPACITY

POPULAR MODELS IN RED

FREIGHT CLASS: 175

MODEL	"A"	"L"	"C"	WEIGHT (LBS.)	SUGG. PRICE
Titan-01	27"	36"	7"	155	\$406.25
Titan-02	27"	42"	7"	165	\$406.25
Titan-03	27"	48"	7"	170	\$406.25
Titan-05	27"	60"	7"	220.00	\$840.00
Titan-06	27"	72"	7"	265	\$850.00
Titan-08	27"	96"	7"	390.00	\$1137.50
Titan-10	20.5"	36"	7"	155	\$406.50
Titan-11	20.5"	42"	7"	160	\$406.50
Titan-12	20.5"	48"	7"	165	\$406.50
Titan-15	20.5"	72"	7"	240.00	\$906.25
Titan-1636	16"	36"	6"	150	\$550.00
Titan-1836	18"	36"	6"	155	\$695.00

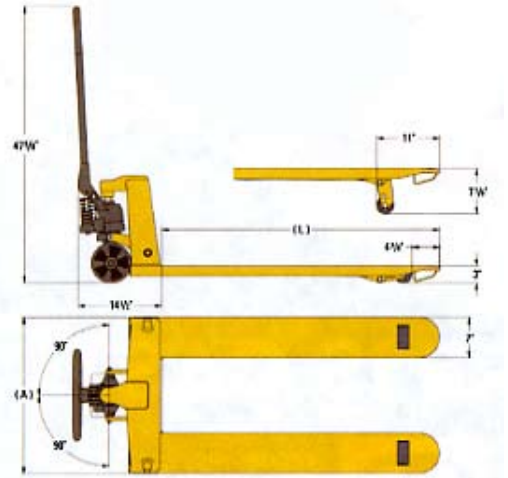

OTHER SIZE PALLET TRUCKS AVAILABLE UPON REQUEST.

# SPECIAL TRUCKS & OPTIONS



**Skid Adaptor** – Transforms the truck for either pallet or skid use. Secures easily in a vertical position.



**Load Backrest** – Built from 1 1/4" tubular steel for added load stability and operator safety.



**Platform/Skid Truck** – Offers a customized solution to various unique applications.



**Dual-Action Drum Brake** – Increases maneuverability and operator safety on uneven floors.



**Freezer Truck** – A special design features anti-corrosion materials for wet, cold and other harsh environments.



**Four Way Hand Pallet Truck with Pallet Stops** – Operator can handle pallets easily in all four directions. Maximizes trailer load density while restricting fork entry in adjoining pallets.

## OPTIONS

OPTIONS	DESCRIPTION	SUGGESTED PRICE
TITANOPT02	3" SKID ADAPTER FOR 27" x 48"	\$275.00
TITANOPT03	3" SKID ADAPTER FOR 20.5" x 36"	\$275.00
TITANOPT04	3" SKID ADAPTER FOR 20.5" x 42"	\$275.00
TITANOPT05	3" SKID ADAPTER FOR 20.5" x 48"	\$275.00
TITANOPT07	48" BACKREST OF 27"W TRUCK	\$175.00
TITANOPT10	60" BACKREST OF 27"W TRUCK	\$195.00
TITANOPT13	AUTOMOTIVE TYPE BRAKE	\$375.00
TITANOPT29	STEEL WHEELS ALL AROUND	\$87.50
TITANOPT28	POLY/STEEL WHEELS ALL AROUND	\$120.00

## LOW PROFILE SERIES

2" LOWERED HEIGHT/ 6.75" RAISED HEIGHT  
5,000LB. CAPACITY

MODEL	"A"	"L"	"C"	WEIGHT (LBS.)	SUGG. PRICE
L50M-03	27"	48"	6"	175	\$768.75
L50M-02	27"	42"	6"	170	\$768.75
L50M-12	20.5"	48"	6"	160	\$768.75

4 WAY ENTRY PALLET  
IS 40"W x 46"L

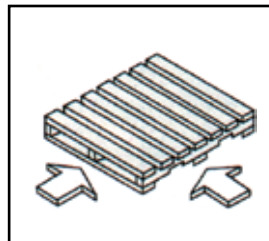

## SPECIAL TRUCKS

FREIGHT CLASS: 175

MODEL	SIZE	FEATURES	CAPACITY (LBS.)	L.H./ R.H.	SUGG. PRICE
L50M-4WAY	33" x 48"	4-WAY ENTRY	5,000	2"/6.75"	\$781.25
L50MU-ULTRA	33" x 48"	1.75" 4-WAY ENTRY	5,000	1.75"/6.50"	\$881.25
L80-03	27" x 48"	HEAVY DUTY	8,000	3.25"/8"	\$1337.50
L50-03FR	27" x 48"	GALV. FREEZER SPECIAL	5,000	3"/7.75"	\$1325.00
TITAN-03BR	27" x 48"	AUTOMOTIVE BRAKE	5,000	3"/7.75"	\$781.25

## LOW PROFILE SERIES

