

PST PLUS PALLET TRUCK

FEATURES:

- DESIGNED SPECIFICALLY FOR LIGHT DUTY, LOW VOLUME APPLICATIONS
- 2,200LB. CAPACITY
- 24V BATTERY POWERED DRIVE
- MANUAL RAISE AND LOWER
- 7"x2" DIAMETER BOLT-ON DRIVE WHEEL
- BUILT-IN BATTERY CHARGER
- BATTERY CHARGE INDICATOR
- STATE OF THE ART CURTIS ELECTRONICS

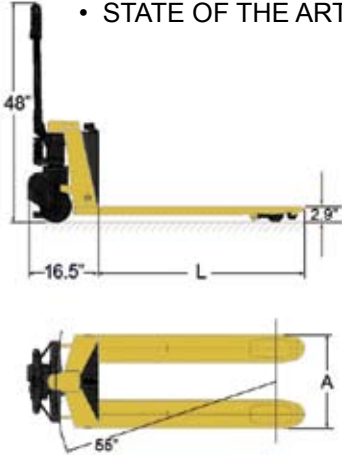

FREIGHT CLASS: 92.5

MODEL	WIDTH (A)	LENGTH (L)	FORK WIDTH	WEIGHT (LBS.)	SUGGESTED PRICE
PSTPLUS-03	27"	48"	6"	235	\$3450.00
PSTPLUS-10	20.5"	36"	6"	185	\$3450.00
PSTPLUS-11	20.5"	42"	6"	205	\$3450.00
PSTPLUS-12	20.5"	48"	6"	225	\$3450.00

PST PALLET TRUCK

POWER-START-TECHNOLOGY™

REVOLUTIONARY CONCEPT IN ERGONOMICS

A SIMPLE PUMP OF THE HANDLE GIVES STEER WHEELS A 1/3 TURN ON START UP TO GET YOUR LOAD ROLLING.



FREIGHT CLASS: 175

MODEL	"A"	"L"	"C"	WEIGHT (LBS.)	SUGGESTED PRICE
PST5000A36	27"	36"	6"	168	\$1062.50
PST5000A42	27"	42"	6"	178	\$1062.50
PST5000A48	27"	48"	6"	188	\$1062.50
PST5000B36	20.5"	36"	6"	163	\$1062.50
PST5000B42	20.5"	42"	6"	165	\$1062.50
PST5000B48	20.5"	48"	6"	173	\$1062.50

