

# LIFT-RITE®

## Weigh Scale - Hand Pallet Truck



### Model WS44-Weigh Scale Hand Pallet Truck

The Lift-Rite Hand Pallet truck with scale combines the controlling function of a very accurate weighing system with the mobility and flexibility of a hand pallet truck. You weigh pallets and containers during transport, at the place of the handling. You save time when checking incoming and outgoing goods.

### Features

- The WS44 is developed for industrial applications and is protected against water, dust and shocks.
- The exchangeable battery module provides for 35 hours of use, and makes it possible to use the hand pallet truck without weighing when charging the battery.
- Quick exchange battery mount (extra battery can be purchased).
- Load cells, cabling IP67 and indicator IP65 protection.
- 10 greasable bushings ensure a long service life.

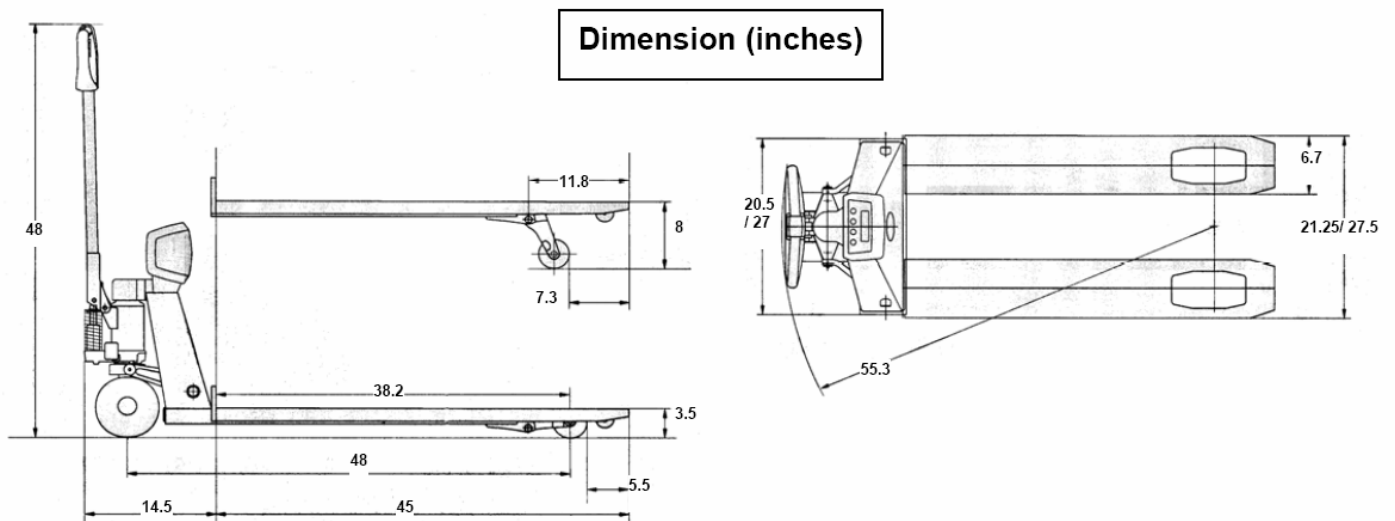

# LIFT-RITE®

## Weigh Scale - Hand Pallet Truck

### Model WS44 Weigh Scale Hand Pallet Truck

Technical details	
Rated Capacity (lbs)	4,400
Fork Frame profile (inch)	27.5 wide x 45 long
Fork height lowered/ raised (inch)	3.5 / 8
Weight (lbs)	231
Steer Wheel (inch)	7 (diameter) x 2 3/8 (width)
Load roller (inch)	3 3/8 (diameter) x 4 (width)
Specifications	
<ul style="list-style-type: none"> <li>• Graduation multi-range:               <ul style="list-style-type: none"> <li>○ 0 - 500 lbs: graduation of 0.5 lbs</li> <li>○ 500 – 1000 lbs: graduation of 1 lbs</li> <li>○ 1000 – 4400 lbs: graduation of 2 lbs</li> </ul> </li> <li>• Maximum inaccuracy: 0.1% of applied weight.</li> <li>• Protection class: Load cells, cabling IP67 and indicator IP65.</li> </ul>	<ul style="list-style-type: none"> <li>• Battery life: up to 35 hours, low voltage indication 5 hours before switch off.</li> <li>• Battery: 12 VDC/ 1.2 Ah, exchangeable.</li> <li>• Charger: 110 Volt/ 12 Vdc</li> </ul>
Functions	
<ul style="list-style-type: none"> <li>• Automatic and Manual zero correction</li> <li>• Gross /net weighing</li> <li>• Automatic and manual tare</li> </ul>	<ul style="list-style-type: none"> <li>• Cumulative totaling, with sequence number</li> <li>• Error message in display</li> <li>• Automatic switch off after 30 minutes of non-use (programmable)</li> </ul>